

# 247B Series 2

## Multi Terrain Loader



### Features

The Cat® 247B Series 2 Multi Terrain Loader, with its radial lift design, delivers excellent digging performance with outstanding drawbar power. Its suspended undercarriage system provides superior traction, flotation and the ability to work in a wide range of underfoot conditions.

The 247B Series 2 features the following:

**Ergonomic Operator Station.** Easy to use pilot operated joystick controls for reduced operator fatigue and increased productivity.

**High Performance Power Train.** Provides high engine horsepower and torque, allowing part-throttle operation for lower sound levels and fuel consumption.

**Advanced Hydraulic System.** Designed for maximum power and reliability.

**Single Level Suspension Undercarriage.** Provides low ground pressure, stability, high traction and fast travel.

**Serviceability.** Easy routine maintenance helps reduce machine downtime for greater productivity.

**Work Tools.** Caterpillar's broad range of performance matched work tools make the Cat Multi Terrain Loader the most versatile machine on the jobsite.

# 247B Series 2 Specifications

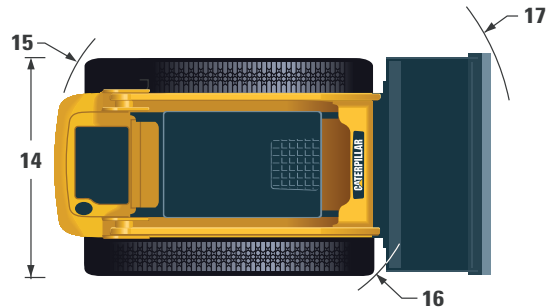
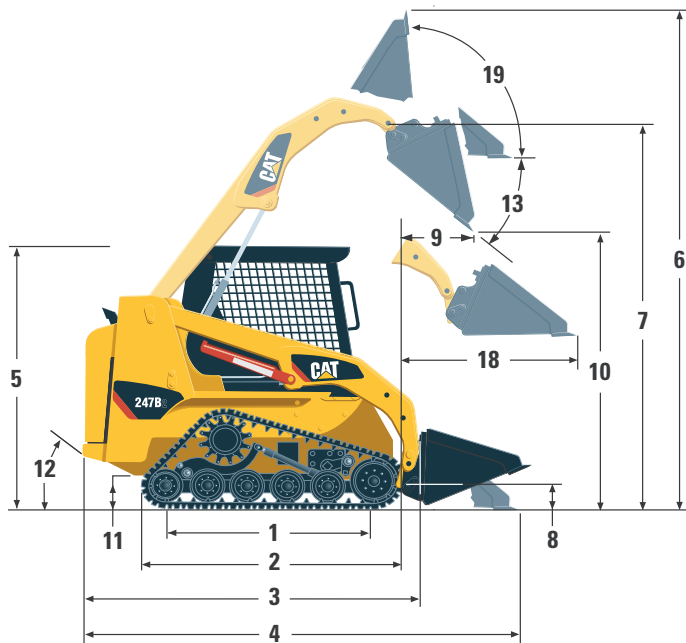

## Dimensions

	mm
1 Length of Track on Ground	1499
2 Overall Length of Track	1899
3 Length without Bucket	2518
4 Length with Bucket on Ground	3285
5 Height to Top of Cab	1990
6 Max. Overall Height	3799
7 Bucket Pin Height at Max. Lift	2862
8 Bucket Pin Height at Carry Position	234
9 Reach at Max. Lift and Dump	625
10 Clearance at Max. Lift and Dump	2134
11 Ground Clearance	267
12 Departure Angle	41°
13 Maximum Dump Angle	40°
14 Vehicle Width	1676
15 Turning Radius from Center – Machine Rear	1356
16 Turning Radius from Center – Coupler	1318
17 Turning Radius from Center – Bucket	2157
18 Max. Reach with Arms Parallel to Ground	1395
19 Rack Back Angle at Max. Height	97°

## Engine

Horsepower (hp) are metric

Engine Model	Cat® 3024C T
Gross Power SAE J1995	46 kW/63 hp
Net Power ISO 9249 at 2600 rpm	42 kW/57 hp
Displacement	2.2 L
Stroke	100 mm
Bore	84 mm

## Weight

Operating Weight	3174 kg
------------------	---------

## Power Train

Max. Travel Speed (Forward or Reverse)	12 km/h
--	---------

## Hydraulic System

Hydraulic Flow – Standard	
Loader Hydraulic Pressure	230 bar
Loader Hydraulic Flow	60 L/min
Hydraulic Power	23 kW/31 hp

## Operating Specifications

Rated Operating Capacity	
35% Tipping Load	650 kg
50% Tipping Load	929 kg
Tipping Load	1949 kg
Breakout Force	18 kN
Ground Contact Area	1.14 m <sup>2</sup>
Ground Pressure	0.27 bar

## Cab

ROPS	ISO 3471:1994
FOPS	ISO 3449 APR98 Level I, ISO 3449:1992 Level I ISO 3449:1992 Level II

## Service Refill Capacities

	Liter
Cooling System	10
Engine Crankcase	10
Fuel Tank	62
Hydraulic System	55
Hydraulic Tank	35

# 247B Series 2 Multi Terrain Loader

## Work Tools

---

- Augers
- Angle Blades
- Brooms
- Cold Planers
- Forks & Carriages
- Grapple Buckets & Forks
- Landscape Rakes
- Landscape Tillers
- Material Handling Arms
- Stump Grinders
- Trenchers
- Snow Blowers
- Vibratory Compactors
- Dozer Blades

## Standard Equipment

---

### Electrical

- Electrical System, 12 V
- Alternator, 85 A
- Ignition Key Start/Stop Switch
- Lights: *Gauge Backlighting, Two Rear Tail Lights, Two Adjustable Front Halogen Lights, Dome Light*

### Operator Environment

- Gauges: *Fuel Level, Hour Meter*
- Operator Warning System Indicators: *Air Filter Restriction, Alternator Output, Armrest Raised/Operator Out of Seat, Engine Coolant Temperature, Engine Oil Pressure, Glow Plug Activation, Hydraulic Filter Restriction, Hydraulic Oil Temperature, Parking Brake Engaged*
- Vinyl Seat
- Pull Down Ergonomic Contoured Armrest
- Control Interlock System, when operator leaves seat or armrest raised: *Hydraulic System Disables, Hydrostatic Transmission Disables, Parking Brake Engages*
- ROPS Cab, Open, Tilt Up
- FOPS, Level I
- Top and Rear Windows
- Headliner, Deluxe
- Floor Mat
- Interior Rear View Mirror
- 12 volt Electric Socket
- Horn

### Power Train

- Cat® 3024C T Stage II Compliant Diesel Engine
- Air Cleaner, Dual Element, Radial Seal
- S-O-S<sup>SM</sup> Sampling Valves, Engine Oil and Hydraulic Oil

## Mandatory Equipment

---

- Quick Coupler, Mechanical or Hydraulic
- Seat Belt, 50 mm or 75 mm
- EU Preparation Package

### Comfort Package (select one of the following):

- Open ROPS (C0): *Static Seat*
- Open ROPS (C1): *Suspension Seat, Cup Holder*
- Enclosed ROPS (C2): *C1 and Heater, Cab Door, Side Windows, Cab Debris Barrier*
- Enclosed ROPS (C3): *C2 and Air Conditioner*

### Performance Package (select one of the following):

- Control Package 1: *High Flow Hydraulics*
- Control Package 2: *On/Off Auxiliary Hydraulics Basic*
- Control Package 3: *Proportional Auxiliary Hydraulics Deluxe*

- Filters, Spin on, Hydraulic
- Filters, Bayonet-type, Fuel and Water Separator
- Tilt Up Radiator/Hydraulic Oil Cooler
- Muffler, Standard
- Spring Applied, Hydraulically Released, Wet Multi Disc Parking Brakes
- Hydrostatic Transmission

### Other

- Engine Enclosure, Lockable
- Extended Life Antifreeze, -36°C
- Machine Tie Down Points (4)
- Support, Lift Arm
- Hydraulic Oil Level Sight Gauge
- Radiator Coolant Level Sight Gauge
- Radiator, Expansion Bottle
- Caterpillar XT™ ToughGuard™ Hose
- Auxiliary, Hydraulics, Continuous Flow
- Heavy Duty, Flat Faced Quick Disconnects
- Split D-Ring to Route Work Tool Hoses Along Side of Left Lift Arm
- Electrical Outlet, Beacon
- Belly Pan Cleanout

## Optional Attachments

---

- Beacon, Rotating
- Engine Block Heater – 120 V or 240 V
- Oil, Hydraulic, Cold Operation
- Paint, Custom
- Backup Alarm
- Heavy Duty Battery, 850 CCA

# 247B Series 2 Multi Terrain Loader

---

For more complete information on Cat products, dealer services, and industry solutions, visit us on the web at [www.cat.com](http://www.cat.com)

HEHX3621 (07/2007) hr

© 2007 Caterpillar -- All Rights Reserved

Materials and specifications are subject to change without notice. Featured machines in photos may include additional equipment. See your Caterpillar dealer for available options.

CAT, CATERPILLAR, their respective logos, "Caterpillar Yellow" and the POWER EDGE™ trade dress, as well as corporate and product identity used herein, are trademarks of Caterpillar and may not be used without permission.

**CATERPILLAR**®  
TODAY'S WORK. TOMORROW'S WORLD.™